



2017

DP80390 IP Core



Pipelined High Performance 8-bit Microcontroller v. 5.02

COMPANY OVERVIEW

Digital Core Design is a leading IP Core provider and a System-on-Chip design house. The company was founded in 1999 and since the very beginning has been focused on IP Core architecture improvements. Our innovative, silicon proven solutions have been employed by over 300 customers and with more than 500 hundred licenses sold to companies like Intel, Siemens, Philips, General Electric, Sony and Toyota. Based on more than 70 different architectures, starting from serial interfaces to advanced micro-controllers and SoCs, we are designing solutions tailored to your needs.

IP CORE OVERVIEW

The DP80390 is an **ultra-high performance, speed optimized** soft core of a single-chip 8-bit embedded controller, intended to operate with **fast** (typically on-chip) and **slow** (off-chip) **memories**. It supports up to 8 MB of linear code space and 16 MB of linear data space. The core has been designed with a special concern about **performance to power consumption ratio**. This ratio is extended by an **Advanced Power Management Unit** – the **PMU**. The DP80390 soft core is 100% binary-compatible with the industry standard 8051 8-bit microcontroller. There are two configurations of the DP80390: **Harvard**, where internal data and program buses are separated and **von Neumann**, with common program and external data bus. The DP80390 has a **Pipelined RISC architecture** and executes **85-200 million instructions per second**. Dhrystone 2.1 benchmark program runs from 11.46 to 15.55 times faster than the original 80C51 at the same frequency. The same C compiler was used for benchmarking of the core vs. the 80C51 with the same settings. This performance can be also exploited to a great advantage in low power applications, where the core can be clocked over ten times slower than the original implementation, without performance depletion. The IP is delivered with **fully automated test bench** and **complete set of tests**, allowing easy package validation at each stage of SoC design flow.

CPU FEATURES

- 100% software compatible with 80390 & 8051 industry standards
 - *LARGE mode – 8051 instruction set*
 - *FLAT mode – 80390 instruction set*
- Pipelined RISC architecture enables to execute instructions **15.55** times faster compared to the standard 8051
- Up to 14.632 VAX MIPS at 100 MHz
- 24 times faster multiplication
- 12 times faster addition
- Up to 256 bytes of internal (on-chip) Data Memory
- Up to 8M bytes of linear Program Memory
 - *64 kB of internal (on-chip) Program Memory*
 - *8 MB external (off-chip) Program Memory*
- Up to 16M bytes of external (off-chip) Data Memory
- User programmable Program Memory Wait States solution for a wide range of memories speed

- User programmable External Data Memory Wait States solution for wide range of memories speed
- De-multiplexed Address/Data bus to allow easy connection to memory
- Dedicated signal for Program Memory writes.
- Interface for additional Special Function Registers
- Fully synthesizable, static synchronous design with positive edge clocking and no internal tri-states
- Scan test ready
- **2.0 GHz virtual** clock frequency in a 0.25u technological process

PERIPHERALS

- **DoCD™ debug unit**
 - *Processor execution control*
 - *Run*
 - *Halt*
 - *Step into instruction*
 - *Skip instruction*
 - *Read-write all processor contents*
 - *Program Counter (PC)*
 - *Program Memory*
 - *Internal (direct) Data Memory*
 - *Special Function Registers (SFRs)*
 - *External Data Memory*
 - *Code execution breakpoints*
 - *up to eight real-time PC breakpoints*
 - *unlimited number of real-time OP CODE breakpoints*
 - *Hardware execution watch-point*
 - *one at Internal (direct) Data Memory*
 - *one at Special Function Registers (SFRs)*
 - *one at External Data Memory*
 - *Hardware watch-points activated at a certain*
 - *address by any write into memory*
 - *address by any read from memory*
 - *address by required data write into memory*
 - *address by required data read from memory*
 - *Unlimited number of software watchpoints*
 - *Internal (direct) Data Memory*
 - *Special Function Registers (SFRs)*
 - *External Data Memory*
 - *Unlimited number of software breakpoints*
 - *Program Memory(PC)*
 - *Automatic adjustment of debug data transfer speed rate between HAD and Silicon*
 - *TTAG or JTAG Communication interface*
- **Power Management Unit**
 - *Power management mode*
 - *Switchback feature*
 - *Stop mode*
- **Interrupt Controller**
 - *2 priority levels*
 - *2 external interrupt sources*
 - *3 interrupt sources from peripherals*
- **Four 8-bit I/O Ports**
 - *Bit addressable data direction for each line*
 - *Read/write of single line and 8-bit group*
- **Two 16-bit timer/counters**
 - *Timers clocked by internal source*
 - *Auto reload 8-bit timers*
 - *Externally gated event counters*
- **Full-duplex serial port**
 - *Synchronous mode, fixed baud rate*
 - *8-bit asynchronous mode, fixed baud rate*
 - *9-bit asynchronous mode, fixed baud rate*
 - *9-bit asynchronous mode, variable baud rate*

DELIVERABLES

- ◆ Source code:
 - VHDL Source Code or/and
 - VERILOG Source Code or/and
 - Encrypted, or plain text EDIF
- ◆ VHDL & VERILOG test bench environment
 - Active-HDL automatic simulation macros
 - ModelSim automatic simulation macros
 - Tests with reference responses
- ◆ Technical documentation
 - Installation notes
 - HDL core specification
 - Datasheet
- ◆ Synthesis scripts
- ◆ Example application
- ◆ Technical support
 - IP Core implementation support
 - 3 months maintenance
 - Delivery of the IP Core and documentation updates, minor and major versions changes
 - Phone & email support

CONFIGURATION

The following parameters of the DP80390 core can be easily adjusted to requirements of a dedicated application and technology. Configuration of the core can be effortlessly done, by changing appropriate constants in the package file. There is no need to change any parts of the code.

- | | |
|--------------------------------------|------------------------|
| ● Internal Program Memory type | - synchronous |
| | - asynchronous |
| ● Internal Program ROM Memory size | - 0 - 64kB |
| ● Internal Program RAM Memory size | - 0 - 64kB |
| ● Internal Program Memory fixed size | - true |
| | - false |
| ● Interrupts | - subroutines location |
| ● Power Management Mode | - used |
| | - unused |
| ● Stop mode | - used |
| | - unused |
| ● DoCD™ debug unit | - used |
| | - unused |

Besides parameters mentioned above, all available peripherals and external interrupts can be excluded from the core, by changing appropriate constants in the package file.

PROGRAM CODE SPACE IMPLEMENTATION

The following figure shows an example Program Memory space implementation in systems with the DP80390 Microcontroller Core. The on-chip Program Memory located in the address space between 0kB and 1kB, is typically used for a BOOT code with system initialization functions. This part of the code is typically implemented as ROM. The on-chip Program Memory located in the address space between 60kB and 64kB, is typically used for timing critical part of the code e.g. interrupt subroutines, arithmetic functions etc. This part of the code is typically implemented as RAM and can be loaded by the BOOT code during initialization phase, from an off-chip memory or through

the RS232 interface from an external device. From the two spaces mentioned above, the program code is executed without wait-states and can achieve top performance of up to 200 million instructions per second (many instructions executed in one clock cycle). The off-chip Program Memory located in the address space between 1kB and 60kB and above 64 kB, is typically used for main code and constants. This part of the code is usually implemented as ROM, SRAM or FLASH device. Due to relatively long access time, the program code executed from devices mentioned earlier must be fetched with additional Wait-States. The number of required Wait-States depends on memory access time and a DP80390 clock frequency. In most cases, the proper number of Wait-States cycles is between 2 and 5. The READY pin can be also dynamically modulated e.g. by an SDRAM controller.

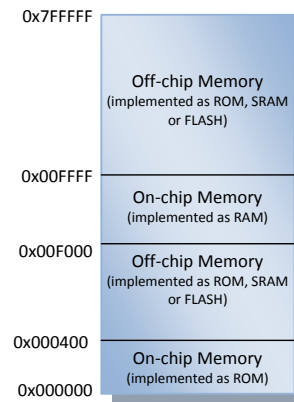

The figure below shows typical Program Memories connections in the system with the DP80390 Microcontroller core.

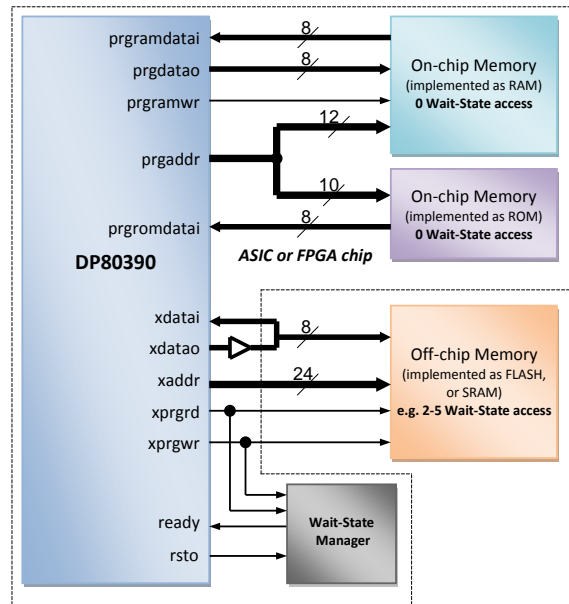

The implementation described above should be treated as an example only. All Program Memory spaces are fully configurable. For timing-critical applications, the whole program code can be implemented as on-chip ROM and (or) RAM and executed without Wait-States, but for some other applications, the whole program code can be implemented as off-chip ROM or FLASH and executed with required number Wait-State cycles.

PINS DESCRIPTION

PIN	TYPE	DESCRIPTION
clk	input	Global clock
reset	input	Global reset
port0i	input	Port 0 input
port1i	input	Port 1 input
port2i	input	Port 2 input
port3i	input	Port 3 input
iprgromsize	input	Size of on-chip RAM CODE
iprgromsize	input	Size of on-chip ROM CODE
prgramdata	input	Data bus from int. RAM prog. memory
prgromdata	input	Data bus from int. ROM prog. memory
sxdmdatai	input	Data bus from sync external data memory SXDM
xdatai	input	Data bus from external memories
ready	input	External memory data ready
ramdatai	input	Data bus from internal data memory
sfrdatai	input	Data bus from user SFR's
int0	input	External interrupt 0
int1	input	External interrupt 1
t0	input	Timer 0 input
t1	input	Timer 1 input
gate0	input	Timer 0 gate input
gate1	input	Timer 1 gate input
rxdi0	input	Serial receiver input 0
tdi	input	DoCD™ TAP data input
tck	input	DoCD™ TAP clock input
tms	input	DoCD™ TAP mode select input
rsto	output	Reset output
port0o	output	Port 0 output
port1o	output	Port 1 output
port2o	output	Port 2 output
port3o	output	Port 3 output
prgaddr	output	Internal program memory address bus
prgdatao	output	Data bus for internal program memory
prgramwr	output	Internal program memory write
sxdmaddr	output	Sync XDATA memory address bus (SXDM)
sxdmdatao	output	Data bus for Sync XDATA memory (SXDM)
sxdmoe	output	Sync XDATA memory read (SXDM)
sxdmwe	output	Sync XDATA memory write (SXDM)
xaddr	output	Address bus for external memories
xdatao	output	Data bus for external memories
xdataz	output	Turn xdata bus into 'Z' state
xprgrd	output	External program memory read
xprgwr	output	External program memory write
xdatard	output	External data memory read
xdatawr	output	External data memory write
ramaddr	output	Internal Data Memory address bus
ramdatao	output	Data bus for internal data memory
ramoe	output	Internal data memory output enable
ramwe	output	Internal data memory write enable
sfraddr	output	Address bus for user SFR's
sfrdatao	output	Data bus for user SFR's
sfroe	output	User SFR's read enable
sfrwe	output	User SFR's write enable
tdo	output	DoCD™ TAP data output
rtck	output	DoCD™ return clock line
debugacs	output	DoCD™ accessing data
coderrun	output	CPU is executing an instruction
pmm	output	Power management mode indicator
stop	output	Stop mode indicator
rxdo0	output	Serial receiver output 0
txd0	output	Serial transmitter output 0

DESIGN FEATURES

◆ PROGRAM MEMORY:

The DP80390 soft core is dedicated for operation with Internal and External Program Memory. Its maximum linear size is equal to 8 MB. Internal Program Memory can be implemented as:

- ROM located in address range between $0000h \div (ROM_{size}-1)$
- RAM located in address range between $(64kB-RAM_{size}) \div FFFFh$

External Program Memory can be implemented as ROM or RAM located in address range between $ROM_{size} \div 8 MB$, excluding area occupied by RAM_{size} .

◆ INTERNAL DATA MEMORY:

The DP80390 can address Internal Data Memory of up to 256 bytes. The Internal Data Memory can be implemented as Single-Port synchronous RAM.

◆ EXTERNAL DATA MEMORY:

The DP80390 soft core can address up to 16 MB of External Data Memory. Extra DPX (*Data Pointer eXtended*) register is used for segments swapping.

◆ USER SPECIAL FUNCTION REGISTERS:

Up to 104 External (user) Special Function Registers (ESFRs) may be added to the DP80390 design. ESFRs are memory mapped into Direct Memory between addresses $0x80$ and $0xFF$, in the same manner as core SFRs and may occupy any address that is not occupied by a core SFR.

◆ WAIT STATES SUPPORT:

The DP80390 soft core is dedicated for operation with wide range of Program and Data memories. Slow Program and External Data memory may assert a memory Wait signal to hold up CPU activity.

SYMBOL

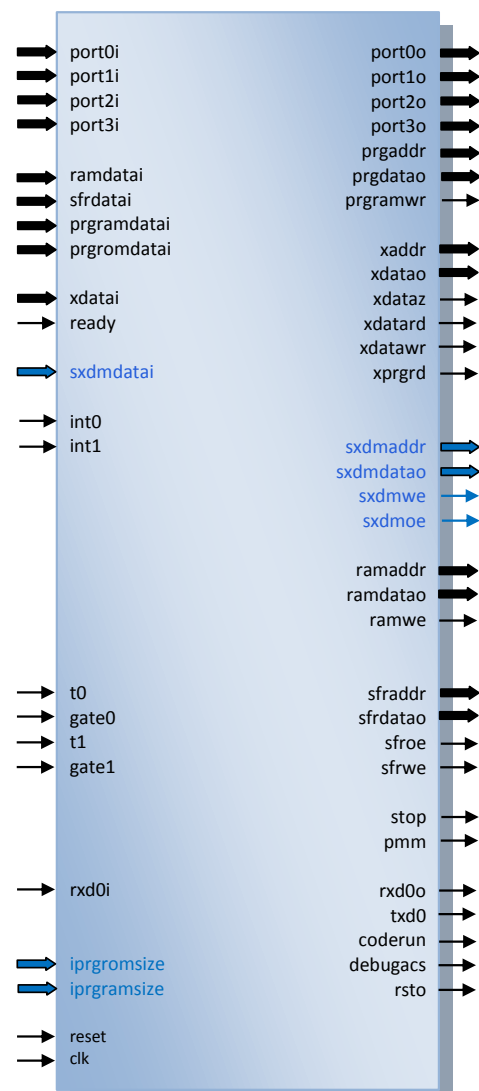

BLOCK DIAGRAM

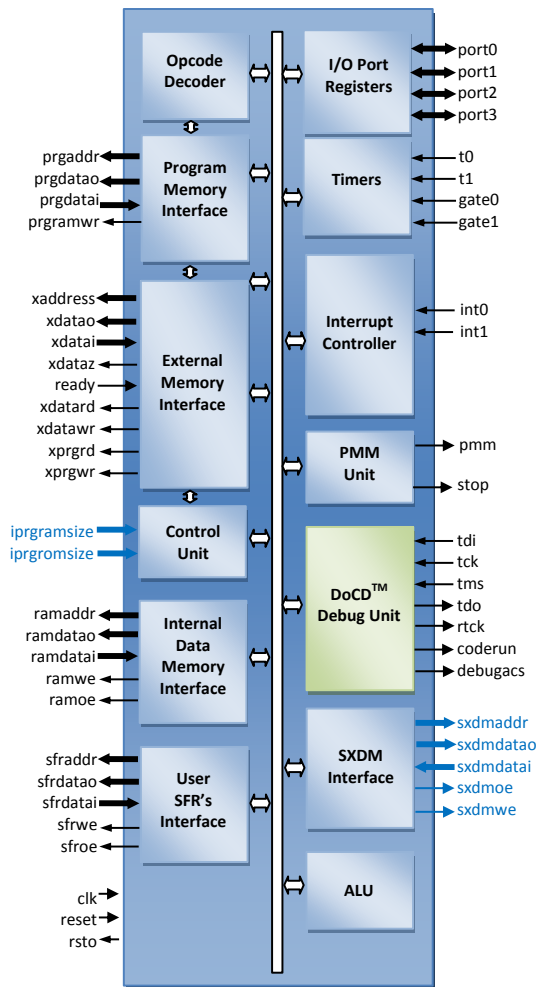

LICENSING

Comprehensible and clearly defined licensing methods **without royalty-per-chip fees** make use of our IP Cores easy and simple.

Single-Site license option – dedicated to small and middle sized companies, which run their business in one place.

Multi-Site license option – dedicated to corporate customers, who operate at several locations. The licensed product can be used in selected company branches.

In all cases the number of IP Core instantiations within a project and the number of manufactured chips are unlimited. The license is royalty-per-chip free. There are no restrictions regarding the time of use.

There are two formats of the delivered IP Core:

- VHDL or Verilog RTL synthesizable [HDL Source code](#)
- FPGA EDIF/NGO/NGD/QXP/VQM [Netlist](#)

UNITS SUMMARY

ALU – Arithmetic Logic Unit - performs arithmetic and logic operations, during execution of an instruction. It contains accumulator (ACC), Program Status Word (PSW), (B) registers

and related logic, like arithmetic unit, logic unit, multiplier and divider.

Opcode Decoder – Performs an opcode decoding instruction and control functions for all other blocks.

Control Unit – Performs the core synchronization and data flow control. This module is directly connected to Opcode Decoder and it manages execution of all microcontroller tasks.

Program Memory Interface – Program Memory Interface contains Program Counter (PC) and related logic. It performs the instructions code fetching. Program Memory can be also written. This feature allows usage of a small boot loader, to load new program into ROM, RAM, EPROM or FLASH EEPROM storage via UART, SPI, I2C or DoCD™ module.

External Memory Interface - Contains memory access related registers, such as Data Page High (DPH), Data Page Low (DPL) and Data Page Pointer (DPP) registers. It performs the external Program and Data Memory addressing and data transfers. Program fetch cycle length can be programmed by the user. This feature is called Program Memory Wait States and it allows core, to work with different speed program memories.

Synchronous eXternal Data Memory (SXDM) Interface – contains XDATA memory access related logic, allowing fast access to synchronous memory devices. It performs the external Data Memory addressing and data transfers. This memory can be used to store large variables, frequently accessed by CPU, improving overall performance of application.

Internal Data Memory Interface – Interface controls access into the internal memory of size up to 256 bytes. It contains 8-bit Stack Pointer (SP) register and related logic.

User SFRs Interface – Special Function Registers interface controls access to the special registers. It contains standard and used defined registers and related logic. User defined external devices can be quickly accessed (read, written, modified), by using all direct addressing mode instructions.

Interrupt Controller – Interrupt Controller module is responsible for the interrupt manage system of the external and internal interrupt sources. It contains interrupt related registers, such as Interrupt Enable (IE), Interrupt Priority (IP) and (TCON) registers.

Timers – System timers module. Contains two 16 bits configurable timers: Timer 0 (TH0, TL0), Timer 1 (TH1, TL1) and Timers Mode (TMOD) registers. In the timer mode, timer registers are incremented every 12 (or 4) CLK periods, when appropriate timer is enabled. In the counter mode, the timer registers are incremented every falling transition on their corresponding input pins (T0, T1), if gates are opened (GATE0, GATE1). T0, T1 input pins are sampled every CLK period. It can be used as clock source for UARTs.

UART0 – Universal Asynchronous Receiver and Transmitter module is full duplex, which means, it can transmit and receive concurrently. Includes Serial Configuration register (SCON), serial receiver and transmitter buffer (SBUF) registers. Its receiver is double-buffered, meaning, it can commence reception of a second byte, before the previously received byte has been read from the receive register. Writing to SBUF0 loads the transmit register and reading SBUF0, reads a physically separate receive register. Works in 3 asynchronous and 1 synchronous modes. UART0 can be synchronized by Timer 1 or Timer 2 (if present in the system).

Ports - Block contains 8051's general purpose I/O ports. Each of the port's pin can be read/written as a single bit or as a 8-bit bus P0, P1, P2, P3.

Power Management Unit – Power Management Unit contains advanced power saving mechanisms with switchback feature, allowing external clock control logic to stop clocking (Stop mode) or run core in lower clock frequency (Power Management Mode), to significantly reduce power consumption. Switchback feature allows UARTs and interrupts to be processed in full speed mode, if enabled. It is highly desirable, when microcontroller is planned to be used in portable and power critical applications.

DoCD™ Debug Unit – it's a **real-time hardware debugger**, which provides debugging capability of a whole SoC system. Unlike other on-chip debuggers, **DoCD™** ensures **non-intrusive debugging** of running application. It can halt, run, step into or skip an instruction, read/write any contents of microcontroller, including all registers, internal and external program memories and all SFRs, including user defined

peripherals. Hardware breakpoints can be set and controlled on program memory, internal and external data memories, as well as on SFRs. Hardware watchpoints can be set and controlled on internal and external data memories and also on SFRs. Hardware watchpoints are executed, if any write/read occurs at particular address, with certain data pattern or without pattern. Two additional pins: CODERUN and DEBUGACS, indicate the state of the debugger and CPU. CODERUN is active, when CPU is executing an instruction. DEBUGACS pin is active, when any access is performed by **DoCD™** debugger. The **DoCD™** system includes **TTAG** or **JTAG interface** and complete set of tools, to communicate and work with core in real time debugging. It is built, as a scalable unit and some features can be turned off by the user, to save silicon and reduce power consumption. When debugger is not used, it is automatically switched to power save mode. Finally, when debug option is no longer used, whole debugger is turned off.

DP8051 FAMILY OVERVIEW

Main features of each DP80C51 family member have been summarized in the table below. It gives a brief member characteristic, helping you to select the most suitable IP Core for your application. You can specify your own peripheral set (including listed below and others) and requests the core modifications.

Design	Program Memory space				Stack space size	Internal Data Memory space	External Data Memory space	External Data / Program Memory Wait States	Power Management Unit Interface for additional SFRs	Interrupt sources	Interrupt levels	Data Pointers	Timer/Counters	UART	I/O Ports	Compare/Capture	Watchdog	Master I ² C Bus Controller	Slave I ² C Bus Controller	SPI	Fixed Point Coprocessor	Floating Point Coprocessor
	Architecture speed grade	on-chip RAM	on-chip ROM	off-chip																		
DP8051CPU	10	64k	64k	64k	256	256	16M	✓	✓	2	2	1	-	-	-	-	-	-	-	-	-	-
DP8051	10	64k	64k	64k	256	256	16M	✓	✓	5	2	1	2	1	4	-	-	-	-	-	-	-
DP8051XP	10	64k	64k	64k	256	256	16M	✓	✓	15	2	2	3	2	4	✓	✓	✓	✓	✓	✓	✓

DP8051 family of Pipelined High Performance Microcontroller Cores

DP80390 FAMILY OVERVIEW

Main features of each DP80390 family member have been summarized in the table below. It gives a brief member characteristic, helping you to select the most suitable IP Core for your application. You can specify your own peripheral set (including listed below and others) and requests the core modifications.

Design	Program Memory space				Stack space size	Internal Data Memory space	External Data Memory space	External Data / Program Memory Wait States	Power Management Unit Interface for additional SFRs	Interrupt sources	Interrupt levels	Data Pointers	Timer/Counters	UART	I/O Ports	Compare/Capture	Watchdog	Master I ² C Bus Controller	Slave I ² C Bus Controller	SPI	Fixed Point Coprocessor	Floating Point Coprocessor
	Architecture speed grade	on-chip RAM	on-chip ROM	off-chip																		
DP80390CPU	10	64k	64k	8M	256	256	16M	✓	✓	2	2	1	-	-	-	-	-	-	-	-	-	-
DP80390	10	64k	64k	8M	256	256	16M	✓	✓	5	2	1	2	1	4	-	-	-	-	-	-	-
DP80390XP	10	64k	64k	8M	256	256	16M	✓	✓	15	2	2	3	2	4	✓	✓	✓	✓	✓	✓	✓

DP80390 family of Pipelined High Performance Microcontroller Cores



CONTACT

Digital Core Design Headquarters:

Wroclawska 94, 41-902 Bytom, POLAND

e-mail: info@dcd.pl

tel.: 0048 32 282 82 66

fax: 0048 32 282 74 37

Distributors:

Please check: <http://dcd.pl/sales>